

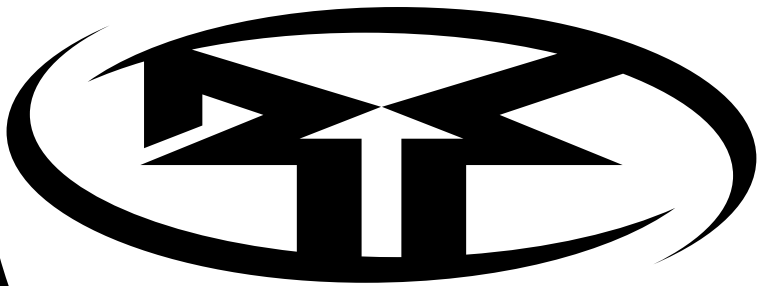

Punch 100.2  
Punch 120.2  
Punch 160.2  
Punch 250.2  
Punch 360.2  
Punch 500.2  
Punch 800.2

Installation  
& Operation



# **PUNCH**

**trans•ana▶**

**2-CHANNEL AMPLIFIERS**

Páginas de Referencia para la Instalación  
Schéma d'Installation  
Installations Beiblatt  
Istruzioni di Installation

Dear Customer,

*Congratulations on your purchase of the world's finest brand of car audio speakers. At Rockford Fosgate we are fanatics about musical reproduction at its best, and we are pleased you chose our product. Through years of engineering expertise, hand craftsmanship and critical testing procedures, we have created a wide range of products that reproduce music with all the clarity and richness you deserve.*

**For maximum performance we recommend you have your new Rockford Fosgate product installed by an Authorized Rockford Fosgate Dealer, as we provide specialized training through Rockford Technical Training Institute (RTTI). Please read your warranty and retain your receipt and original carton for possible future use.**

*Great product and competent installations are only a piece of the puzzle when it comes to your system. Make sure that your installer is using 100% authentic installation accessories from Connecting Punch in your installation. Connecting Punch has everything from RCA cables and speaker wire to Power line and battery connectors. Insist on it! After all, your new system deserves nothing but the best.*

*To add the finishing touch to your new Rockford Fosgate image order your Rockford wearables, which include everything from T-shirts and jackets to hats and sunglasses.*

*To get a free brochure on Rockford Fosgate products and Rockford wearables, in the U.S. call 480-967-3565 or FAX 480-967-8132. For all other countries, call +001-480-967-3565 or FAX +001-480-967-8132.*

### **PRACTICE SAFE SOUND™**

**CONTINUOUS EXPOSURE TO SOUND PRESSURE LEVELS OVER 100dB MAY CAUSE PERMANENT HEARING LOSS. HIGH POWERED AUTOSOUND SYSTEMS MAY PRODUCE SOUND PRESSURE LEVELS WELL OVER 130dB. USE COMMON SENSE AND PRACTICE SAFE SOUND.**

If, after reading your manual, you still have questions regarding this product, we recommend that you see your Rockford Fosgate dealer. If you need further assistance, you can call Customer Service at 1-800-669-9899 and ask for Technical Support. Be sure to have your serial number, model number and date of purchase available when you call.

The serial number can be found on the outside of the box. Please record it in the space provided below as your permanent record. This will serve as verification of your factory warranty and may become useful in recovering your Fanatic P System if it is ever stolen.

Serial Number: \_\_\_\_\_

Model Number: \_\_\_\_\_

# TABLE OF CONTENTS

---

Specifications .....	2
Introduction .....	4
Punch Amplifier Accessory Pack .....	4
2-Channel Feature Chart .....	5
Design Features .....	6
Installation Considerations .....	10
Mounting Location .....	11
Battery and Charging .....	12
Wiring the System .....	12
Installation .....	14
System Diagrams .....	20
Installation Troubleshooting .....	21
Warranty Information .....	23
International Information .....	24

## GETTING STARTED

Welcome to Rockford Fosgate! This manual is designed to provide information for the owner, salesperson and installer. For those of you who want quick information on how to install this product, please turn to the **Installation Section** of this manual or refer to the icons listed below. Other information can be located by using the Table of Contents. We, at Rockford Fosgate, have worked very hard to make sure all the information in this manual is current. But, as we are constantly finding new ways to improve our product, this information is subject to change without notice.



Sections marked  
**INSTALLATION**  
include "slam dunk"  
wiring connections



Sections marked  
**TROUBLESHOOTING**  
include recommendations for  
curing installation problems

Visit our website for the latest information on all Rockford products.

# SPECIFICATIONS

Specifications subject to change without notice

	PUNCH 100	PUNCH 120	PUNCH 160	PUNCH 250	PUNCH 360	PUNCH 500	PUNCH 800
<b>DYNAMIC POWER RATING</b> (IHF-202 Standard) Measured at 14.4 volts MONO into a 4 ohm load PER CHANNEL into a 2 ohm load PER CHANNEL into a 4 ohm load	160Wx1 80Wx2 50Wx2	200Wx1 94Wx2 64Wx2	236Wx1 113Wx2 77Wx2	320Wx1 160Wx2 100Wx2	450Wx1 210Wx2 140Wx2	710Wx1 330Wx2 210Wx2	960Wx1 480Wx2 240Wx2
<b>CONTINUOUS POWER RATING</b> (MEASURED AT 13.8V) RMS continuous power PER CHANNEL both channels driven into a 4 ohm load from 20 to 20,000Hz with less than 0.05% THD+N (total Harmonic Distortion)	25Wx2	30Wx2	40Wx2	62.5Wx2	90Wx2	125Wx2	200Wx2
RMS continuous power PER CHANNEL both channels driven into a 2 ohm load from 20 to 20,000Hz with less than 0.1% THD+N (total Harmonic Distortion)	50Wx2	60Wx2	80Wx2	125Wx2	180Wx2	250Wx2	400Wx2
RMS continuous power MONO both channels driven into a 4 ohm load from 20 to 20,000Hz with less than 0.1% THD+N (total Harmonic Distortion)	100Wx1	120Wx1	160Wx1	250Wx1	360Wx1	500Wx1	800Wx1
<b>SIGNAL to NOISE RATIO</b> (A-weighted)	>100dB	>100dB	>100dB	>100dB	>100dB	>100dB	>100dB
CROSSOVER SLOPE	12DB/octave	12DB/octave	12DB/octave	12DB/octave	12DB/octave	12DB/octave	12DB/octave
CROSSOVER FREQUENCY	80Hz	80Hz	50-Hz-210Hz	50-Hz-210Hz	50-Hz-210Hz	50-Hz-210Hz	50-Hz-210Hz

# SPECIFICATIONS

Specifications subject to change without notice

## DIMENSIONS

(end caps installed)

	PUNCH 100	PUNCH 120	PUNCH 160	PUNCH 250	PUNCH 360	PUNCH 500	PUNCH 800
	2.4"	2.4"	2.4"	2.4"	2.4"	2.4"	2.4"
	(6.09cm) H	((6.09cm) H	(6.09cm) H	(6.09cm) H	(6.09cm) H	(6.09cm) H	(6.09cm) H
	9.9"	9.9"	9.9"	9.9"	9.9"	9.9"	9.9"
	(25.15cm) W	(25.15cm) W	(25.15cm) W	(25.15cm) W	(25.15cm) W	(25.15cm) W	(25.15cm) W
	10.4"	10.4"	10.4"	11.4"	12.4"	13.4"	18.4"
	(26.42 cm) L	(26.42 cm) L	(26.42 cm) L	(28.96 cm) L	(31.5 cm) L	(34.04 cm) L	(46.74 cm) L

## FREQUENCY

**RESPONSE (+ 0.5dB)**

20 Hz-20kHz	20 Hz-20kHz	20 Hz-20kHz	20 Hz-20kHz	20 Hz-20kHz	20 Hz-20kHz	20 Hz-20kHz	20 Hz-20kHz
-------------	-------------	-------------	-------------	-------------	-------------	-------------	-------------

**BANDWIDTH (+ 0.3dB)**

10Hz-250Hz	10Hz-200Hz	10Hz-200Hz	10Hz-200Hz	10Hz-200Hz	10Hz-200Hz	10Hz-200Hz	10Hz-200Hz
------------	------------	------------	------------	------------	------------	------------	------------

## DAMPING FACTOR @4Ω

at output connection

>200	>200	>200	>200	>200	>200	>200	>200
------	------	------	------	------	------	------	------

**SLEW RATE**

30 volts $\mu$ s	30 volts $\mu$ s	30 volts $\mu$ s	30 volts $\mu$ s	30 volts $\mu$ s	30 volts $\mu$ s	30 volts $\mu$ s	30 volts $\mu$ s
------------------	------------------	------------------	------------------	------------------	------------------	------------------	------------------

**IM DISTORTION**

<0.5%	<0.5%	<0.5%	<0.5%	<0.5%	<0.5%	<0.5%	<0.5%
-------	-------	-------	-------	-------	-------	-------	-------

## SOURCE UNIT COMPATIBILITY

(+15dB gain overlap)

All	All	All	All	All	All	All	All
-----	-----	-----	-----	-----	-----	-----	-----

## INPUT SENSITIVITY

(0+dB gain overlap)

200mv ~ 4v	200mv ~ 4v	200mv ~ 4v	200mv ~ 4v	200mv ~ 4v	200mv ~ 4v	200mv ~ 4v	200mv ~ 4v
------------	------------	------------	------------	------------	------------	------------	------------

**PROTECTION**NOMAD- Internal analog computer output protection circuitry limits power in case of overload. Thermal switch shuts down the amplifier in case of overheating

## BATTERY FUSE RATING

(external to amplifier)

15A	20A	20A	30A	40A	50A	60A*
-----	-----	-----	-----	-----	-----	------

**FUSE TYPE**

ATC	ATC	ATC	ATC	ATC	AGU	AGU
-----	-----	-----	-----	-----	-----	-----

## EQUALIZATION

**(45Hz Punch Bass)**

N/A	Adjustable	Variable	Variable	Variable	Variable	Variable
-----	------------	----------	----------	----------	----------	----------

**INPUT IMPEDANCE**

20k $\Omega$	20k $\Omega$	20k $\Omega$	20k $\Omega$	20k $\Omega$	20k $\Omega$	20k $\Omega$
--------------	--------------	--------------	--------------	--------------	--------------	--------------

\* recommended fuse not supplied

# INTRODUCTION

---

Rockford engineers designed the Punch 2-channel amplifiers to withstand the rugged automotive environment while delivering superior sound quality in a flexible, reliable, and efficient package. TRANS•ANA is a low voltage circuit in the preamp stage of all Punch amplifiers that lets the music sound crystal clear and very real, even when played at high volume levels. This is matched with TOPAZ, a unique grounding circuit used to eliminate noise problems associated with car audio systems and their installation. Flexibility is accomplished with the use of a built-in crossover. The use of a protection circuit called NOMAD, along with MOSFET and DSM (Discrete Surface Mount) technologies improve amplifier efficiency. The result of these components give the Punch amplifier awesome sound quality in a “Bullet Proof” package. An explanation of these technologies, most of which are exclusively designed and patented by Rockford, are described in the Technical Design Features.

## PUNCH AMPLIFIER ACCESSORY PACK

---

The accessory pack shipped with the Punch 2-channel amplifiers includes the mounting hardware necessary to secure the amp to the vehicle and to attach the end caps to the amplifier.

Installation & Operation Manual

Punch Verification Certificate

- (4) Amplifier mounting screws (#8 x 3/4" Phillips)
- (1) ATC Inline Fuseholder (Punch 120, 160, 250, 360)
- (1) AGU Inline Fuseholder (Punch 500)
- (2) ATC 15 Amp Fuse (Punch 100 & Punch 120)
- (1) ATC 20 Amp Fuse (Punch 160)
- (1) ATC 30 Amp Fuse (Punch 250)
- (1) ATC 40 Amp Fuse (Punch 360)
- (1) AGU 50 Amp Fuse (Punch 500)
- (1) Remote Punch Bass (except Punch 100 and 120)
- (1) Allen wrench 9/64"
- (1) Allen wrench 3/32"

**Note:** Refer to the Specification section of this manual for recommended Punch 800 fuse size.

# PUNCH 2-CHANNEL AMPLIFIER FEATURE CHART

PUNCH AMPLIFIER MODEL	100	120	160	250	360	500	800
# of Channels	2	2	2	2	2	2	2
Stable into (stereo/bridged)	2Ω/4Ω	2Ω/4Ω	2Ω/4Ω	2Ω/4Ω	2Ω/4Ω	2Ω/4Ω	2Ω/4Ω
<b>CIRCUITRY<sup>1</sup></b>							
TRANS•ana - circuit topology	X	X	X	X	X	X	X
MEHSA - heat dissipating topology	X	X	X	X	X	X	X
TOPAZ - patented noise eliminating circuitry <sup>3</sup>	X	X	X	X	X	X	X
DSM - discrete surface mount	X	X	X	X	X	X	X
MOSFETS - power supply & output devices		X	X	X	X	X	X
NOMAD - protection circuit	X	X	X	X	X	X	X
<b>FEATURES</b>							
Die Cast Heatsink	X	X	X	X	X	X	X
Hi - level Inputs - for factory radios	X	X	X	X	X	X	X
RCA Inputs - for after market radios	X	X	X	X	X	X	X
Pwr/Spk Screw Terminals	X	X	X	-	-	-	-
Pwr/Spk Block Terminals	-	-	-	X	X	X	X
Adjustable Punch Bass (0.dB/+6dB/+12dB@45Hz)	X	-	-	-	-	-	-
Variable Punch Bass (0dB~+18dB@45Hz) (Remote)	-	X	X	X	X	X	X
Adjustable Xover (120Hz HP/80Hz LP)	-	X	-	-	-	-	-
Variable Xover (50Hz - 210Hz)	-	-	-	HP/FULL/LP <sup>4</sup>	HP/FULL/LP <sup>4</sup>	HP/FULL/LP <sup>4</sup>	HP/FULL/LP <sup>4</sup>
Crossover Slope (Butterworth)	12dB	12dB	12dB	12dB	12dB	12dB	12dB

- 1 Additional information on features, specifications and system designs can be found at: [www.rockfordfosgate.com](http://www.rockfordfosgate.com)
- 2 Trans•nova is patented under "U.S. Patent No. 4,467,288"
- 3 TOPAZ is patented under "U.S. Patent No. 5,751,823"
- 4 HP = 12dB/octave High-Pass / LP = 12dB/octave Low-Pass / FULL = Full Range

## DESIGN FEATURES

---

### Punch 100 2-channel

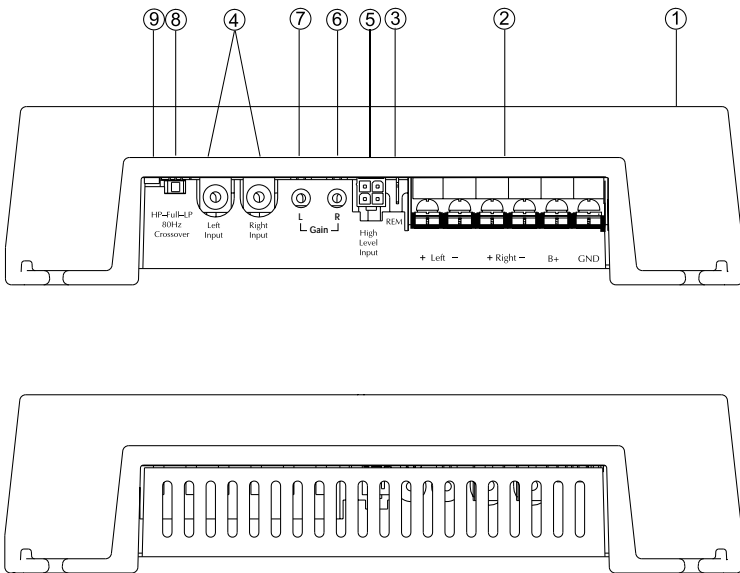



# DESIGN FEATURES

## Punch 120 2-channel

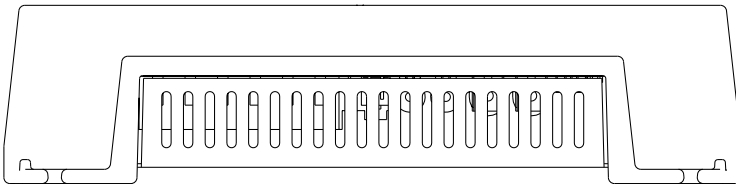
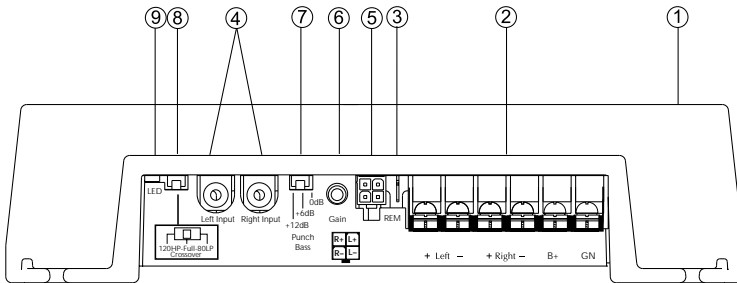

## Punch 160 2-channel

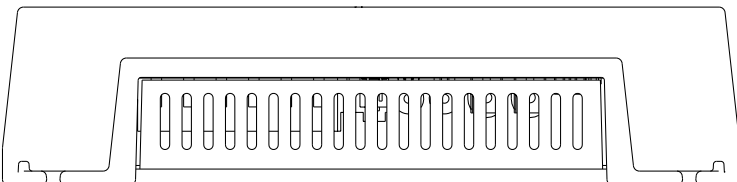
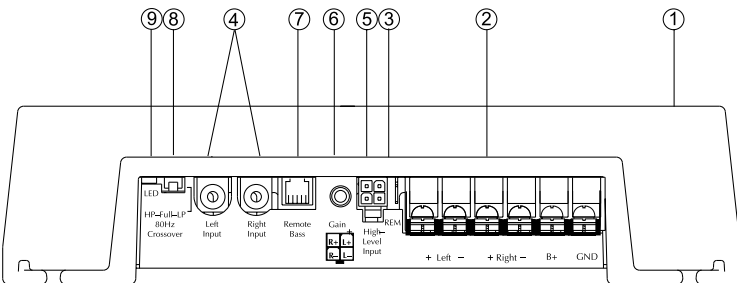

**Punch 250**  
2-channel

**Punch 360**  
2-channel

**Punch 500**  
2-channel

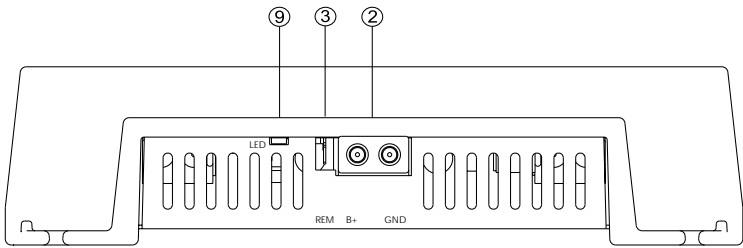
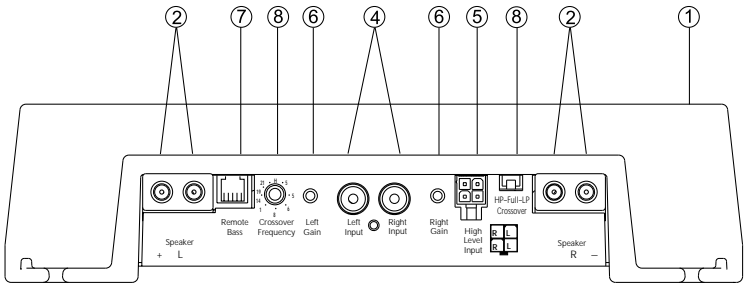

**Punch 800**  
2-channel

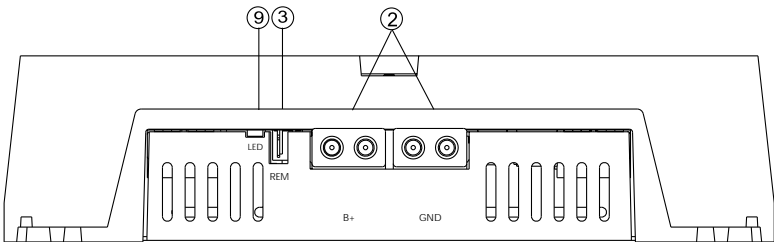
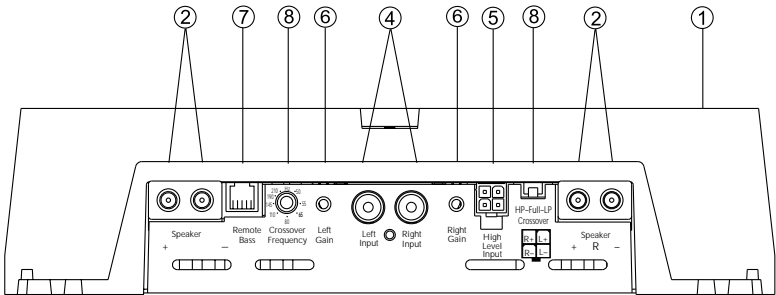

1. **Cast Aluminum Heatsink** – The cast aluminum heatsink of the Punch amplifier dissipates heat generated by the amplifier's circuitry. The inherent advantage of casting provides a 30% improvement of cooling over conventional extrusion heatsink designs.
2. **Speaker/Power Terminals** – These gold-plated connectors are used for the connection of speaker and power wire and are immune to corrosion that can cause signal degradation. The **Punch 120** and **Punch 160** utilize a barrier strip that will accept #10 spade lugs or bare speaker and power wires sized from 10-18 AWG. The **Punch 250**, **Punch 360**, **Punch 500**, and **Punch 800** utilize heavy duty terminal block connectors that will accept bare wires size from 8-18AWG.
3. **REM Terminal** – This spade terminal is used to remotely turn-on and turn-off the amplifier when +12V DC is applied.
4. **RCA Input Jacks** – The industry standard RCA jack provides an easy connection for signal level input. They are gold-plated to resist the signal degradation caused by corrosion.
5. **High Level Inputs** – The high level inputs use a detachable connector terminated with 20 AWG leads. These inputs should be used if the source unit has only speaker line (high level) outputs and not RCA outputs.
6. **Gain Control** – The input gain control is preset to match the output of most source units. They can be adjusted to match output levels from a variety of source units. For assistance setting the gain correctly, contact Technical Support at 1-800-669-9899.
7. **Punch Bass** – The Punch Bass helps correct for acoustical deficiencies in the listening environment. The Punch Bass allows a narrow band adjustment at 45Hz to help reproduce full range sound without excessive boost. The **Punch 120** utilizes a switch that is adjustable at 0dB/+6dB/+12dB increments. The **Punch 160**, **Punch 250**, **Punch 360**, **Punch 500**, and **Punch 800** utilize a **Remote Bass** control that is variable from 0dB to +18dB.
8. **Internal Crossover** – The internal crossover is used to delegate a specific range of frequencies to the speaker system for optimum performance. The crossover can perform three functions: High-Pass (HP), Low-Pass (LP), or Full Range (FULL). The **Punch 120** and **Punch 160** utilize a 12dB/octave Butterworth crossover fixed at 120Hz HP and 80Hz LP. The **Punch 250**, **Punch 360**, **Punch 500**, and **Punch 800** utilize a 12dB/octave Butterworth crossover variable from 50Hz to 210Hz.
9. **LED Power Indicator** – The LED illuminates when the unit is turned on.

# INSTALLATION CONSIDERATIONS

---

The following is a list of tools you will need for installing the Punch amplifier:

- Allen wrenches 9/64" & 3/32" (included)
- Wire strippers
- Electric hand drill w/assorted bits
- 17' (518.16cm) Red Power Wire
- 12' (365.76cm) Remote Turn-On Wire
- 1.5' (45.72cm) Black Grounding Wire
- Voltmeter
- Battery post wrench
- Wire cutters
- Assorted connectors
- Wire crimpers

This section focuses on some of the vehicle considerations for installing your new Punch amplifier. Checking your battery and present sound system, as well as pre-planning your system layout and best wiring routes will save installation time. When deciding how to lay out your new system, be sure that each component will be easily accessible for making adjustments.

Before beginning any installation, be sure to follow these simple rules:

1. Be sure to carefully read and understand the instructions before attempting to install the amplifier.
2. **For safety**, disconnect the negative lead from the battery prior to beginning the installation.
3. For easier assembly, we suggest you run all wires prior to mounting your amplifier in place.
4. Route all of the RCA cables close together and away from any high current wires.
5. Use high quality connectors for a reliable installation and to minimize signal or power loss.
6. **Think before you drill!** Be careful not to cut or drill into gas tanks, fuel lines, brake or hydraulic lines, vacuum lines or electrical wiring when working on any vehicle.
7. Never run wires underneath the vehicle. Running the wires inside the vehicle provides the best protection.
8. Avoid running wires over or through sharp edges. Use rubber or plastic grommets to protect any wires routed through metal, especially the firewall.
9. **ALWAYS** protect the battery and electrical system from damage with proper fusing. Install a fuseholder and appropriate fuse on the +12V power wire within 18" (45.7 cm) of the battery terminal.
10. When grounding to the chassis of the vehicle, scrape all paint from the metal to ensure a good, clean ground connection. Grounding connections should be as short as possible and always be connected to metal that is welded to the main body, or chassis, of the vehicle.

# MOUNTING LOCATION

---

The mounting location and position of your amplifier will have a great effect on its ability to dissipate the heat generated during normal operation. The design of our cast aluminum heatsink serves to easily dissipate the heat generated over a wide range of operating conditions. However, to maximize the performance of your amplifier, care should be taken to ensure adequate ventilation.

## Trunk Mounting

Mounting the amplifier vertically on a surface with the fin grooves running up and down will provide the best cooling of the amplifier.

Mounting the amplifier on the floor of the trunk will work but provides less cooling capability than vertical mounting.

Mounting the amplifier upside down to the rear deck of the trunk will not provide proper cooling and will severely affect the performance of the amplifier and is strongly **not** recommended.

## Passenger Compartment Mounting

Mounting the amplifier in the passenger compartment will work as long as you provide a sufficient amount of air for the amplifier to cool itself. If you are going to mount the amplifier under the seat of the vehicle, you must have at least 1" (2.54cm) of air gap around the amplifier's heatsink.

Mounting the amplifier with less than 1" (2.54cm) of air gap around the amplifier's heatsink in the passenger compartment will not provide proper cooling and will severely affect the performance of the amplifier and is strongly **not** recommended.

## Engine Compartment Mounting

Rockford Fosgate amplifiers should **never** be mounted in the engine compartment. Not only will this void your warranty but could create an embarrassing situation caused by the ridicule from your friends.

# BATTERY AND CHARGING

---

Amplifiers will put an increased load on the vehicle's battery and charging system. We recommend checking your alternator and battery condition to ensure that the electrical system has enough capacity to handle the increased load of your stereo system. Stock electrical systems which are in good condition should be able to handle the extra load of any Rockford amplifier without problems, although battery and alternator life can be reduced slightly. To maximize the performance of your Rockford Fosgate amplifier, we suggest the use of a heavy duty battery and an energy storage capacitor.

# WIRING THE SYSTEM

---

**CAUTION:** *Avoid running power wires near the low level input cables, antenna, power leads, sensitive equipment or harnesses. The power wires carry substantial current and could induce noise into the audio system.*

- **For safety**, disconnect the negative lead from the battery prior to beginning the installation.

1. Plan the wire routing. Take care when running signal level RCA cables to keep them close together but isolated from the amplifier's power cables and any high power auto accessories, especially electric motors. This is done to prevent coupling the noise from radiated electrical fields into the audio signal. When feeding the wires through the firewall or any metal barrier, protect them with plastic or rubber grommets to prevent short circuits. Leave the wires long at this point to adjust for a precise fit at a later time.
2. Prepare the **Power** cable for attachment to the amplifier by stripping 1/2" of insulation from the end of the wire. Insert the bared wire into the B+ terminal and tighten the set screw to secure the cable in place.

**NOTE:** *The B+ cable MUST be fused 18" or less from the vehicle's battery. Install the fuseholder under the hood and prepare the cable ends as stated above. Connections should be water tight.*

Trim the power cable within 18" of the battery and strip 1/2" of insulation from the end of the wire. **Cut the wire loop that is attached to the fuseholder in half and splice the fuse into the power line using appropriate inline connectors.** Use the section of cable that was trimmed earlier and connect it to the other end of the fuseholder.

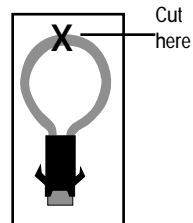

3. Strip 1/2" from the battery end of the power cable and crimp a large ring terminal to the cable. Use the ring terminal to connect to the battery positive terminal. **Do not install the fuse at this time.**
4. Prepare the **Ground** cable for attachment to the amplifier by stripping 1/2" of insulation from the end of the wire. Insert the bared wire into the GND terminal and tighten the set screw to secure the cable in place. Prepare the chassis ground by scraping any paint from the metal surface and thoroughly clean the area of all dirt and grease. Strip the other end of the wire and attach a ring connector. Fasten the cable to the chassis using a non-anodized screw and a star washer.
5. Prepare the **REM** turn-on wire for connection to the amplifier by stripping 1/2" of insulation from the wire end. Insert the bared wire into the REM terminal and tighten the set screw to secure the cable into place. Connect the other end of the REM wire to a switched 12 volt positive source. The switched voltage is usually taken from the source unit's auto antenna or the accessory lead. If the source unit does not have these outputs available, the recommended solution is to wire a mechanical switch in line with a 12 volt source to activate the amplifier.
6. Securely mount the amplifier to the vehicle or amp rack. Be careful not to mount the amplifier on cardboard or plastic panels. Doing so may enable the screws to pull out from the panel due to road vibration or sudden vehicle stops.
7. Connect the source signal to the amplifier by plugging the RCA cables/high level inputs into the input jacks at the amplifier.
8. Connect the speakers. Strip the speaker wires 1/2" and insert into the speaker terminal and tighten the set screw to secure into place. Be sure to maintain proper speaker polarity. ***DO NOT chassis ground any of the speaker leads as unstable operation may result.***
9. Perform a final check of the completed system wiring to ensure that all connections are accurate. Check all power and ground connections for frayed wires and loose connections which could cause problems.



## Using the RCA Inputs -OR- High Level Inputs

All Models

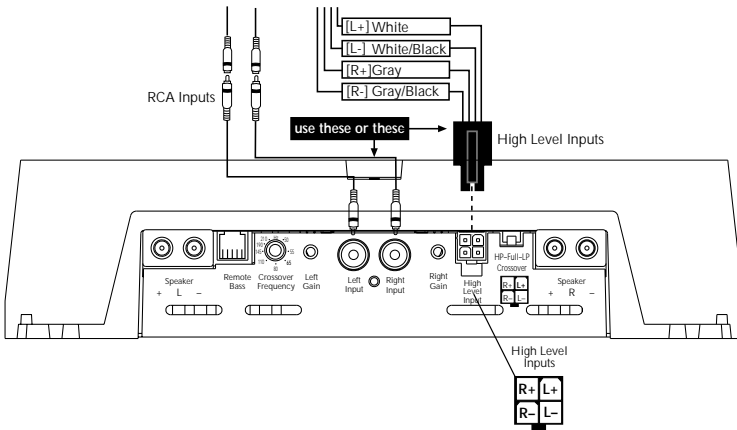

- **High Level Inputs** connect directly to radio's speaker outputs
- **RCA Inputs** connect to radio's RCA preamp outputs

**CAUTION:** Use only one input configuration. Using both the High Level Inputs & RCA Inputs will cause undesirable operation.





## Power Connections

Punch 100

Punch 120  
2-channel

Punch 160

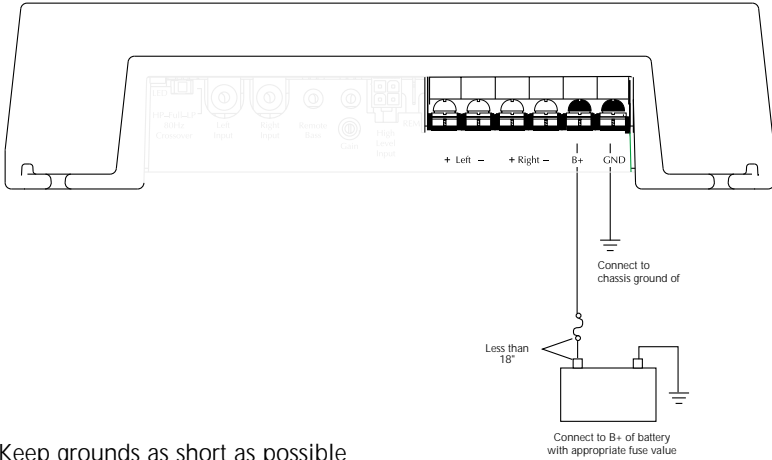

## Bridged/Mono Mode

Punch 100

Punch 120  
2-channel

Punch 160

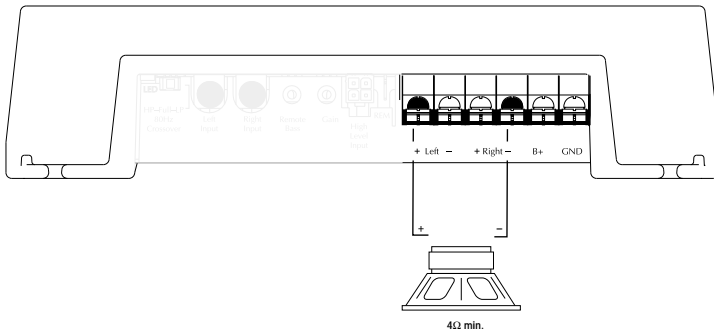

- **RCA** inputs are connected to *both left and right* channels
- **Gain** for left and right channels are *set equally* to balance the subwoofer
- **Impedance** for mono channel should be *4Ω minimum*
- **Crossover** can be set for High-Pass (HP), Low-Pass (LP) or Full Range (FULL)

# INSTALLATION



## 2-Channel Mode

Punch 100    Punch 120    Punch 160  
2-channel

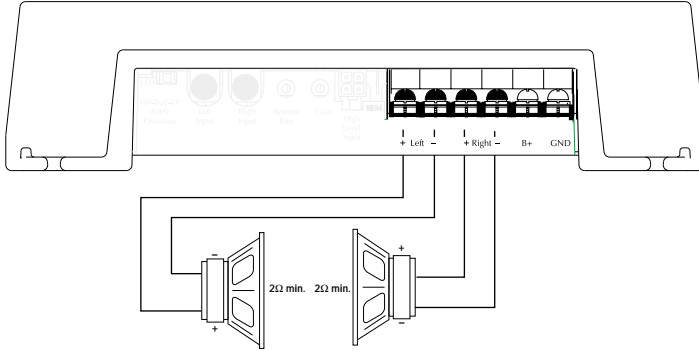

- RCA inputs are connected to *both left and right* channels
- Gain for left and right channels operate *independently*
- Impedance for each channel should be  $2\Omega$  minimum
- Crossover can be set for High-Pass (HP), Low-Pass (LP) or Full Range (FULL)

## 3-Channel Mode

Punch 100    Punch 120    Punch 160  
2-channel

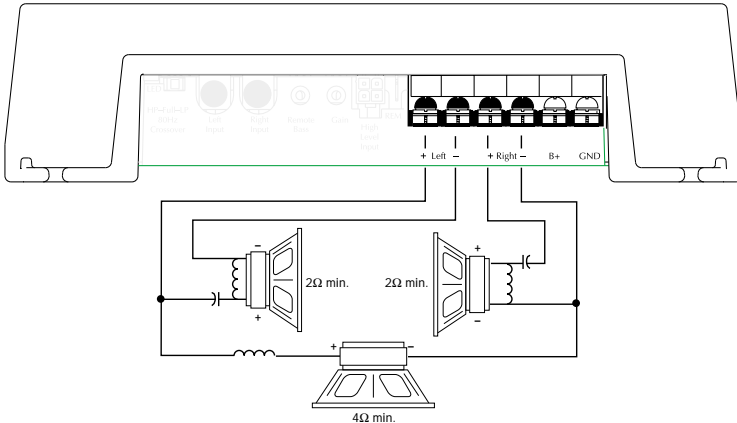

- RCA inputs are connected to *both left and right* channels
- Gain for left and right channels are *set equally* to balance the subwoofer
- Impedance for each channel should be  $2\Omega$  minimum
- Impedance for mono channel should be  $4\Omega$  minimum
- Crossover is set for *Full Range*
- **Passive Crossovers** are needed for proper stereo/mono operation



## Power Connections

Punch 250

Punch 360  
2-channel

Punch 500

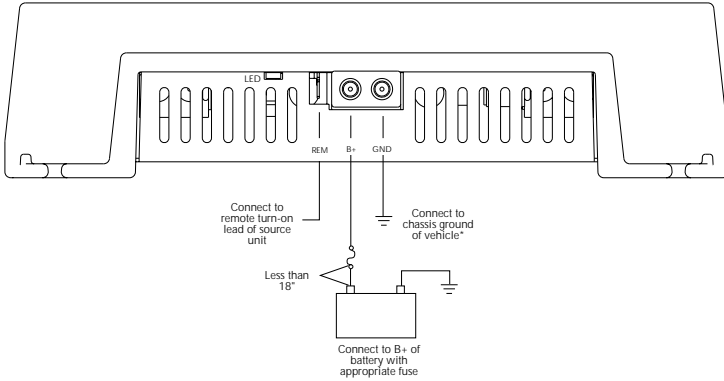

\*Keep grounds as short as possible

## Bridged/Mono Mode

Punch 250 Punch 360 Punch 500 Punch 800  
2-channel

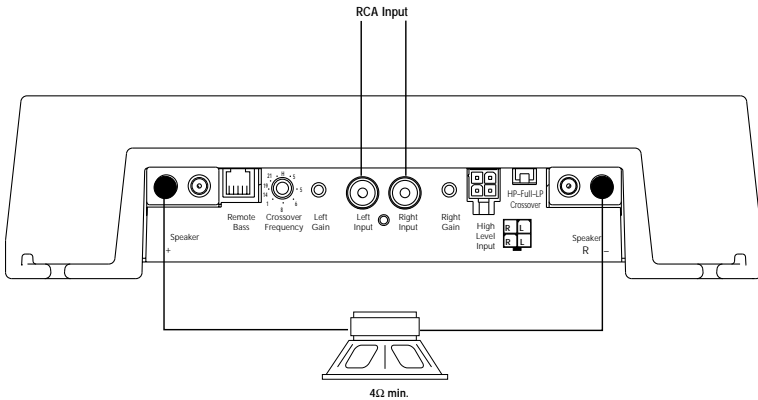

- RCA inputs are connected to *both left and right* channels
- **Gain** for left and right channels are *set equally* to balance the subwoofer
- **Impedance** for mono channel should be *4Ω minimum*
- **Crossover** can be set for High-Pass (HP), Low-Pass (LP) or Full Range (FULL)

# INSTALLATION



## 2-Channel Mode

Punch 250 Punch 360 Punch 500 Punch 800  
2-channel

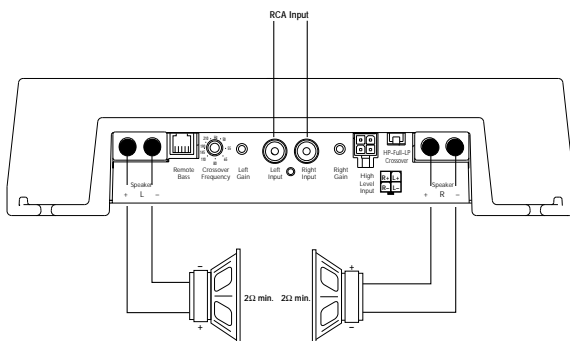

- RCA inputs are connected to *both left and right* channels
- **Gain** for left and right channels operate *independently*
- **Impedance** for each channel should be  $2\Omega$  *minimum*
- **Crossover** can be set for High-Pass (HP), Low-Pass (LP) or Full Range (FULL)

## 3-Channel Mode

Punch 250 Punch 360 Punch 500 Punch 800  
2-channel

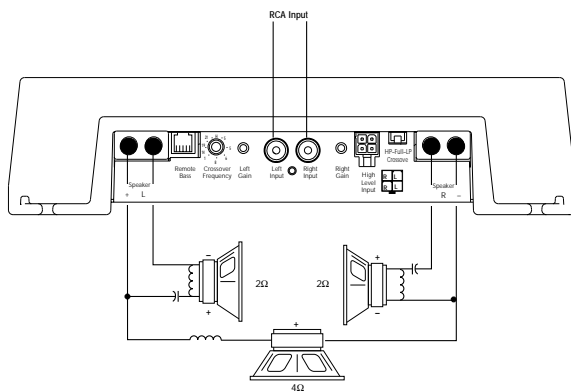

- RCA inputs are connected to *both left and right* channels
- **Gain** for left and right channels are *set equally* to balance the subwoofer
- **Impedance** for each channel should be  $2\Omega$  *minimum*
- **Impedance** for mono channel should be  $4\Omega$  *minimum*
- **Crossover** is set for *Full Range*
- **Passive Crossovers** are needed for proper stereo/mono operation



## Power Connections

**Punch 800**  
2-channel

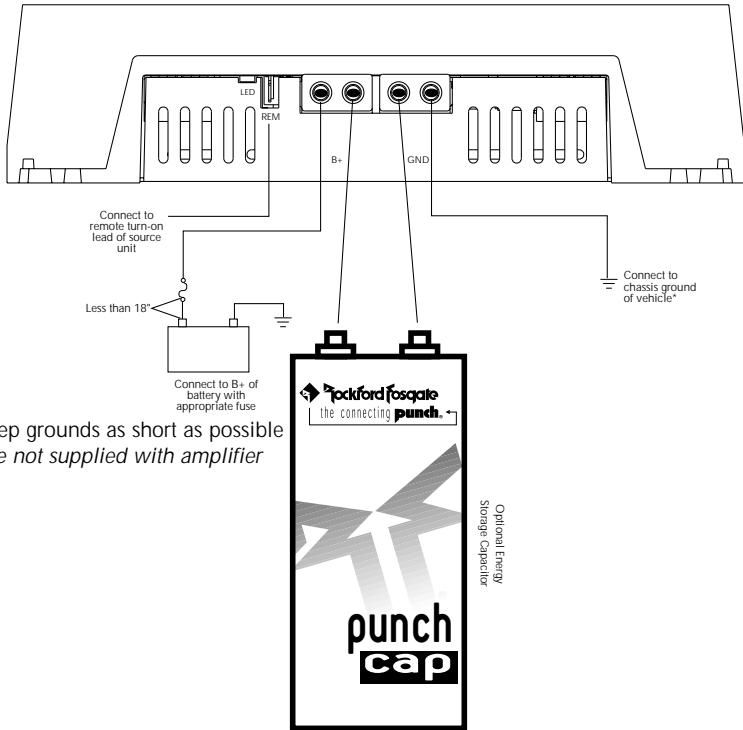

\*Keep grounds as short as possible  
*Fuse not supplied with amplifier*

Maximize any Rockford Fosgate High Performance amplifier by installing a charging capacitor.

# SYSTEM DIAGRAMS

## 2-Way System

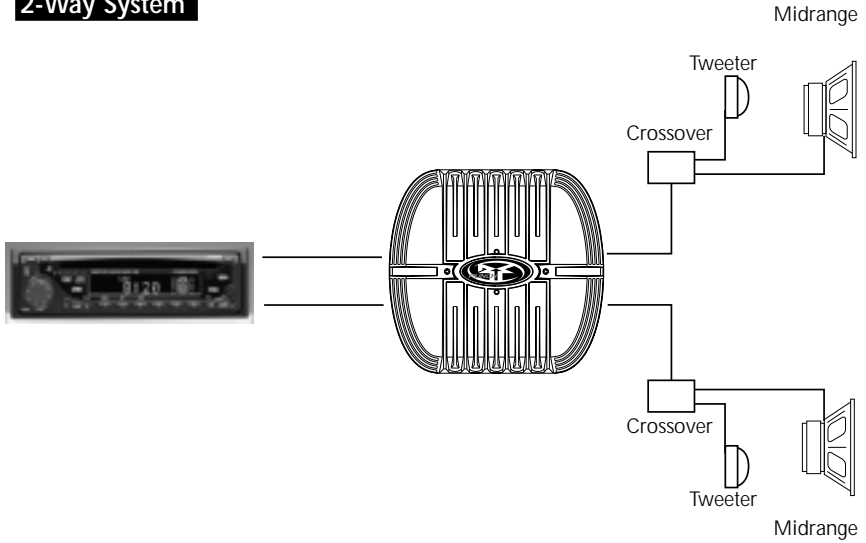

## Remote Punch Bass

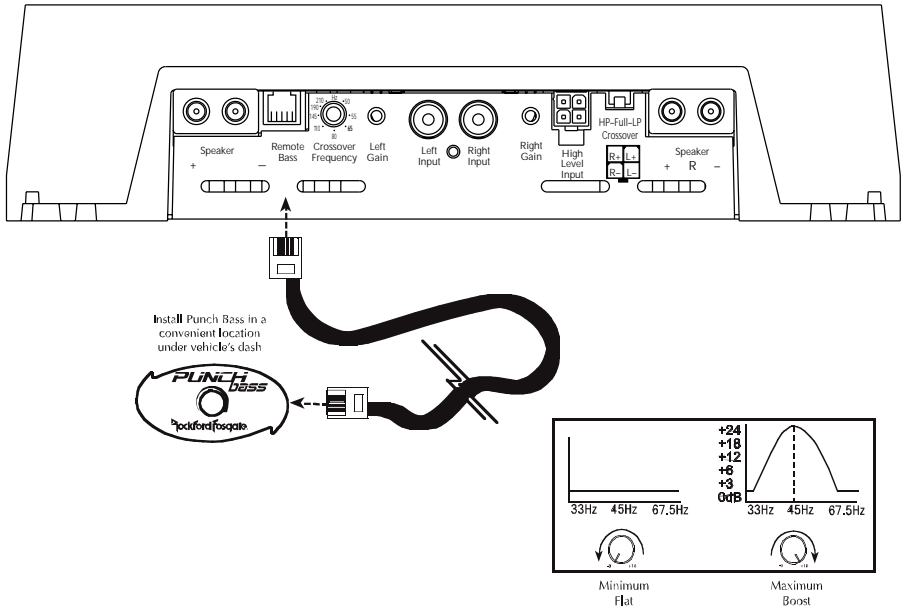

# INSTALLATION TROUBLESHOOTING

---



*If you are having problems after installation follow the Troubleshooting procedures below.*

## **Procedure 1: Check Amplifier for proper connections.**

Verify that POWER light is on. If POWER light is on skip to Step 2, if not continue.

1. Check in-line fuse on battery positive cable. Replace if necessary.
2. Verify that Ground connection is connected to clean metal of the vehicle's chassis. Repair/replace if necessary.
3. Verify there is 10.5 - 15.5 Volts of current present at the positive battery and remote turn-on cable. Verify quality connections for both cables at amplifier, stereo, and battery/fuseholder. Repair/replace if necessary.

## **Procedure 2: Check Amplifier for audio output.**

1. Connect a single 4 or 8 ohm test speaker directly to each output channel amplifier. Verify speakers in car are good and wiring between amplifier and speakers, including connectors are good. Repair/replace if necessary.
2. Verify good RCA/high-level input connections at stereo and amplifier. Check entire length of cables for kinks, splices, etc. Test RCA/high-level inputs for AC current with stereo on. Repair/replace if necessary.
3. Disconnect RCA/high-level input from amplifier. Connect RCA/high-level input from test stereo directly to amplifier input.

## **Procedure 3: Check Amplifier if you experience Turn-on Pop.**

1. Disconnect input signal to amplifier and turn amplifier on and off.
2. If the noise is eliminated, connect the REM lead of amplifier to source unit with a delay turn-on module.

*OR*

1. Use a different 12 Volt source for REM lead of amplifier (i.e. battery direct).
2. If the noise is eliminated, use a relay to isolate the amplifier from noisy turn-on output.

**Procedure 4: Check Amplifier if you experience excess Engine Noise.**



1. Route all signal carrying wires (RCA, Speaker cables) away from power and ground wires.

*OR*

2. Bypass any and all electrical components between the stereo and the amplifier(s). Connect stereo directly to input of amplifier. If noise goes away the unit being bypassed is the cause of the noise.

*OR*

3. Remove existing ground wires for all electrical components. Reground wires to different locations. Verify that grounding location is clean, shiny metal free of paint, rust etc.

*OR*

4. Add secondary ground cable from negative battery terminal to the chassis metal or engine block of vehicle.

*OR*

5. Have alternator and battery load tested by your mechanic. Verify good working order of vehicle electrical system including distributor, spark plugs, spark plug wires, voltage regulator etc.



# LIMITED WARRANTY INFORMATION

---

Rockford Corporation offers a limited warranty on Rockford Fosgate products on the following terms:

- **Length of Warranty**  
3 years on electronics                      90 days on electronic B-stock (receipt required)  
1 year on source units                      90 days on speaker B-stock (receipt required)  
1 year on speakers
- **What is Covered**  
This warranty applies only to Rockford Fosgate products sold to consumers by Authorized Rockford Fosgate Dealers in the United States of America or its possessions. Product purchased by consumers from an Authorized Rockford Fosgate Dealer in another country are covered only by that country's Distributor and not by Rockford Corporation.
- **Who is Covered**  
This warranty covers only the original purchaser of Rockford product purchased from an Authorized Rockford Fosgate Dealer in the United States. In order to receive service, the purchaser must provide Rockford with a copy of the receipt stating the customer name, dealer name, product purchased and date of purchase.
- **Products found to be defective** during the warranty period will be repaired or replaced (with a product deemed to be equivalent) at Rockford's discretion.
- **What is Not Covered**
  1. Damage caused by accident, abuse, improper operations, water, theft
  2. Any cost or expense related to the removal or reinstallation of product
  3. Service performed by anyone other than Rockford or an Authorized Rockford Fosgate Service Center
  4. Any product which has had the serial number defaced, altered, or removed
  5. Subsequent damage to other components
  6. Any product purchased outside the U.S.
  7. Any product not purchased from an Authorized Rockford Fosgate Dealer
- **Limit on Implied Warranties**  
Any implied warranties including warranties of fitness for use and merchantability are limited in duration to the period of the express warranty set forth above. Some states do not allow limitations on the length of an implied warranty, so this limitation may not apply. No person is authorized to assume for Rockford Fosgate any other liability in connection with the sale of the product.
- **How to Obtain Service**  
Please call 1-800-669-9899 for Rockford Customer Service. You must obtain an RA# (Return Authorization number) to return any product to Rockford Fosgate. You are responsible for shipment of product to Rockford.

Ship to: **Electronics**  
Rockford Corporation  
Warranty Repair Department  
2055 E. 5th Street  
Tempe, AZ 85281  
RA#: \_\_\_\_\_

Ship to: **Speakers**  
Rockford Acoustic Design  
(Receiving-speakers)  
609 Myrtle N.W.  
Grand Rapids, MI 49504  
RA#: \_\_\_\_\_

LEA DETENIDAMENTE LAS SIGUIENTES INSTRUCCIONES DE INSTALACION DEL PRODUCTO. EVITARA POSIBLES DAÑOS A VD., AL VEHICULO O AL PRODUCTO.

## INTRODUCCIÓN — ESPAÑOL

---

Los ingenieros de Rockford han diseñado los amplificadores Punch para ofrecer en el difícil entorno de un automóvil una calidad de sonido superior en un producto flexible, fiable y eficiente. Trans•ana es un circuito de baja tensión en la etapa de preamplificación de los amplificadores Punch que permite que la música suene limpia y cristalina y muy real, incluso a altos niveles de audición. Esto se complementa con el TOPAZ, un circuito exclusivo de masa utilizado para eliminar los ruidos asociados con las instalaciones de car-audio. La flexibilidad está garantizada con el uso de la crossover incorporada. La fiabilidad se refuerza con el uso de un circuito de protección llamado NOMAD, mientras que los MOSFET y la tecnología DSM (montaje discreto en superficie) aumentan la eficiencia del amplificador. La combinación de todos estos componentes dan al amplificador Punch una impresionante calidad de sonido en un chasis discreto. Más adelante encontrará más explicaciones de todas estas tecnologías, la mayoría de ellas usadas en exclusiva y patentadas por Rockford.

## UBICACIÓN PARA EL MONTAJE

---

### Montaje en el Malatero

Monte el amplificador verticalmente con las líneas del radiador orientadas de arriba hacia abajo. De esta manera conseguirá la mejor ventilación.

### Montaje en el Compartimento de Pasajeros

El montaje en el compartimento de pasajeros será eficiente en función de la ventilación que tenga el amplificador. Si va a instalar el amplificador bajo un asiento deberá dejar al menos 2.5cm libres sobre la carcasa del amplificador.

### Instalación

Por seguridad, desconecte el terminal negativo de la batería antes de comenzar la instalación.

### Terminal B+

El cable B+ debe ir provisto de un fusible a una distancia no mayor de 45cm de la batería. Prepare el cable e instale el portafusibles en el compartimento del motor. Las conexiones han de ser impermeables.

## Terminal GND

Prepare un trozo de cable para usarlo como toma de masa. Prepare un punto de masa en el chasis rascando y eliminando la pintura de la superficie de metal y limpielo de toda suciedad asegure el cable al chasis con un tornillo.

## Terminal REM

Conecte el cable REM a un punto de +12V con mutable. La señal se suele coger de la salida auto antena del radio cassette si este no tiene salida remote.

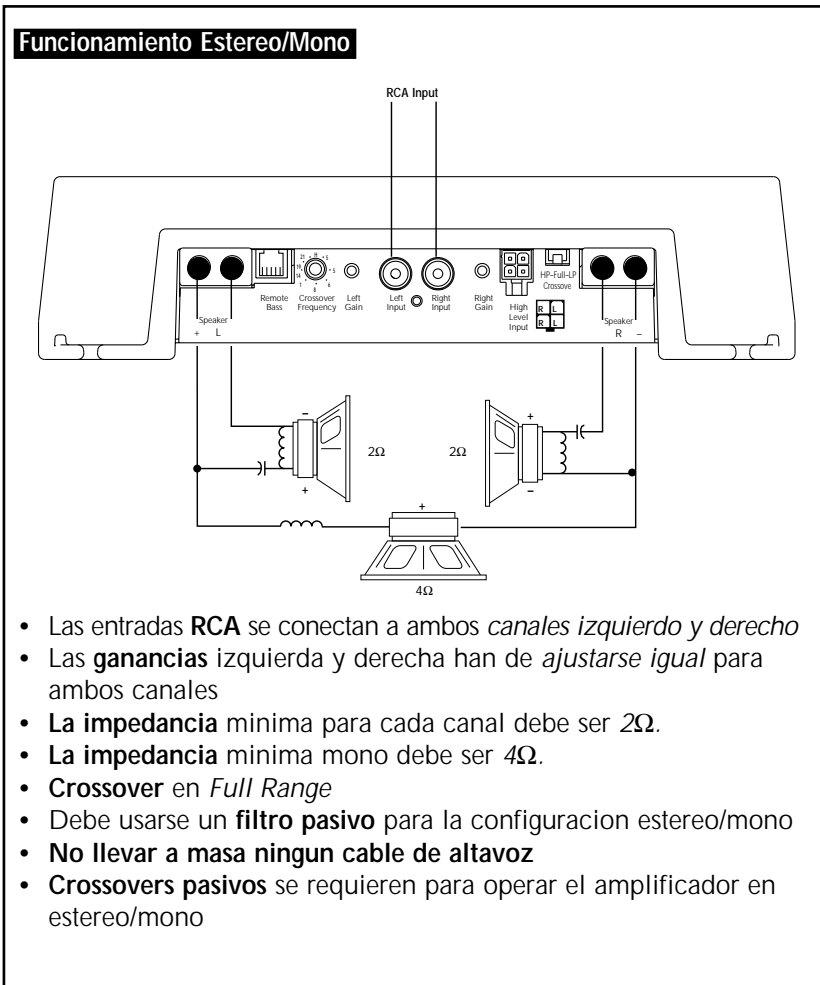

**ATTENTION: Veuillez lire les instructions suivantes pour l'installation de cet amplificateur. Ne pas les suivre pourrait causer des blessures ou endommager le véhicule.**

## **INTRODUCTION — FRANÇAIS**

---

Les ingénieurs de Rockford Fosgate ont conçu l'amplificateur Punch pour supporter l'environnement rude de l'automobile en délivrant une qualité de son supérieure dans un ensemble efficace, fiable et flexible. Trans•ana est un circuit de bas voltage dans l'étage de préamplification de tous les amplificateurs Punch qui reproduit un son musical clair comme du cristal et très réel, même à très haut volume. Ceci est accompagné du TOPAZ, un circuit unique employé pour éliminer les problèmes de bruits parasites associés aux systèmes audiobile et leur installation. La flexibilité est assurée par l'emploi d'une crossover incorporée.

La fiabilité est garantie grâce au circuit de protection NOMAD, la technologie MOSFET et DSM (Composants Montés en Surface) améliorent l'efficacité de l'amplificateur.

L'ensemble de ces atouts donne à l'amplificateur Punch une qualité de son inégalable sous une carrosserie "pare-balles."

Vous trouverez de plus amples informations sur ces technologies, exclusivement conçues et brevetées par Rockford, dans la rubrique technique.

## **MONTAGE**

---

### **Montage dans le coffre**

Monter l'amplificateur verticalement avec les rainures de haut en bas ce qui lui permet de refroidir plus facilement.

### **Montage dans l'habitacle**

Monter l'amplificateur dans l'habitacle ne pose aucun problème, du moment qu'il y ait assez d'air pour le refroidir. Si vous montez l'ampli en dessous du siège, prévoyez 3 cm d'air autour du radiateur.

### **Installation**

Pour votre sécurité, déconnectez la borne négative de la batterie du véhicule avant de commencer l'installation.

### **Terminal B+**

Il est impératif qu'il y ait un fusible sur le câble pour la connexion à la masse. Préparez le châssis en grattant la peinture de la surface métallique et nettoyez la saleté et l'huile. Attachez le câble au châssis avec une vis.

## Terminal GND

Préparez une longueur de câble pour la connexion à la masse. Préparez le châssis en grattant la peinture de la surface métallique et nettoyez la saleté et l'huile. Attachez le câble au châssis avec une vis.

## Terminal REM

Connectez le fil REM à une commande 12 volts positive de la source. La commande 12 volts est habituellement prise sur la sortie antenne électrique de la source ou la commande accessoire. Si la source ne dispose pas de ces sorties, nous vous recommandons d'installer un interrupteur qui fournira un positif 12 volts au REM de l'amplificateur.

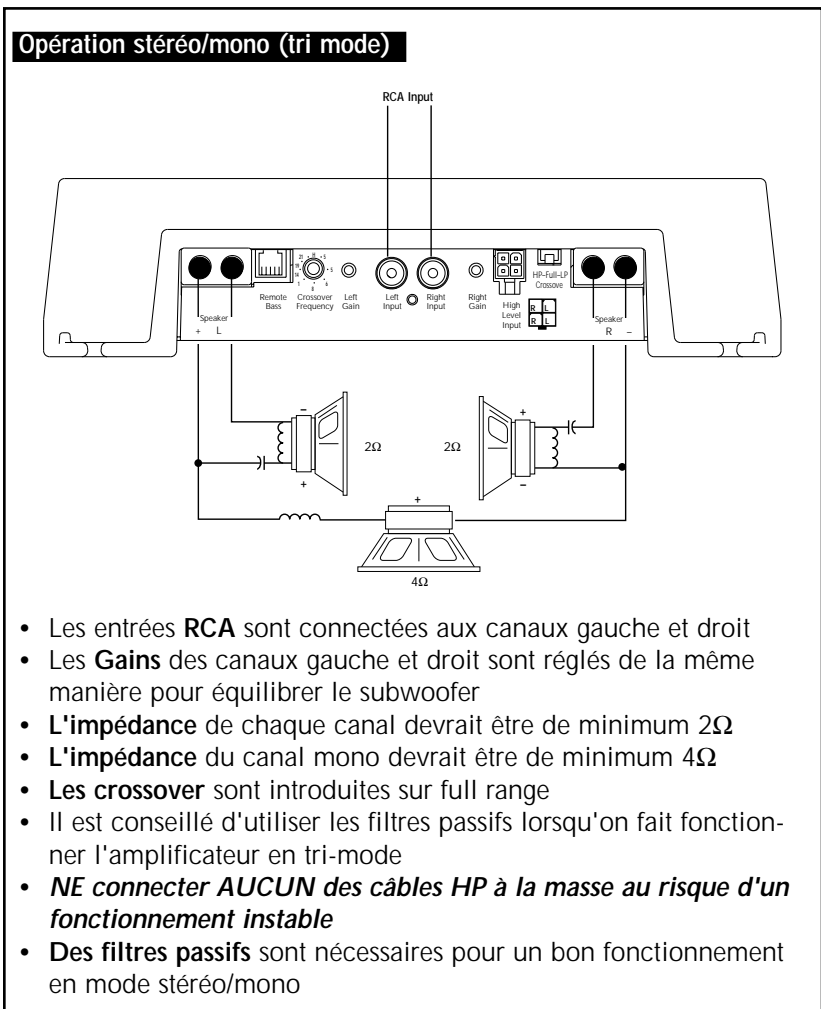

**BITTE LESEN SIE DIESE GEBRAUCHSANLEITUNG ZUERST SORGFÄLTIG DURCH. DAS KANN SIE VOR DEM FALSCHEN EINSATZ, AUSFALLEN ODER SOGAR BESCHÄDIGUNG DES PRODUKTES ODER IHRES FAHRZEUGES SCHÜTZEN.**

## **EINLEITUNG — DEUTSCH**

---

Rockford Ingenieure haben die Punch Verstärker entwickelt. Mit höchstem Technologie-Standart, hervorragender Klangqualität, einfacher Handhabung und bester Servicefreundlichkeit Trans•ana ist eine Nieder-Volt Schaltung im Vorverstärkerteil aller Punch Verstärker die für kristallklaren Klang auch bei sehr hohen Lautstärken sorgt. TOPAZ, eine einzigartige Erdungsschaltung verhindert und unterdrückt Einstreuungen und Störungen die nur allzu oft Car Audio Systeme beeinträchtigen. Flexibilität durch die Vielfalt der Aktivweiche mit ihren crossover, lange Lebensdauer durch die Schutzschaltung NOMAD und der Einsatz von MOSFET Transistoren und DSM (Discrete Surface Mount), machen diese Verstärker so effizient. Das Ergebnis all dieser Komponenten machen Punch-Verstärker so einzigartig und in ihrer Klangqualität nahezu unschlagbar. Eine genauere Beschreibung dieser Technologien, die größtenteils einzigartig und von Rockford patentiert sind, finden Sie unter Technical Design Features.

## **EINBAUORT**

---

### **Im Fahrzeugkofferraum**

Der vertikale Einbau der Endstufen, das bedeutet, daß die Kühlrippen von oben nach unten verlaufen, gibt dem Verstärker die beste Kühlung.

### **Auf der Beifahrerseite**

Sollte der Verstärker auf der Beifahrerseite montiert werden, so ist es sehr wichtig, für eine ausreichende Kühlung zu sorgen. Sollte der Verstärker z.B. unter dem Beifahrersitz montiert werden, sollte dem Kühlkörper mindestens ein Luftspalt von 3 cm bleiben, um so für eine ausreichende Kühlung zu sorgen.

### **Einbau**

Zur Sicherheit klemmen Sie den Negativ-Pol der Batterie während des gesamten Einbaues ab.

### **B+ Anschluß**

Die Plus-Leitung MUB ca. 40 cm nach dem Plus-Pol der Batterie abgesichert sein. Preparieren Si die Kabellängen und montieren Sie den Sicherungshalter im Motorraum. ALLE Verbindungen müssen wasserdicht sein.

## GND Anschluss

Preparieren Sie Ihr Kabel für die Negativ Leitung (Erdung). Preparieren Sie die Anschlussstelle des Erdungskabels, indem Sie das Metall gründlich reinigen und vom Lack befreien. Befestigen Sie nun die Erdung an dieser Stelle mit einer Schraube.

## REM Anschluss

Verbinden Sie das Ein- und Ausschaltungskontroll-Kabel mit Ihrem Radio (12 Volt positiv). Normalerweise verwenden Sie hierfür die Ant.-Remote Ihres Radios oder ein eigens dafür vorgesehenes Kabel (Amp-Remote). Sollte Ihr Radio diesen Anschluss nicht besitzen, so verwenden Sie eine 12 Volt Spannung, die Sie durch einen Schalter ein- und ausschalten können.

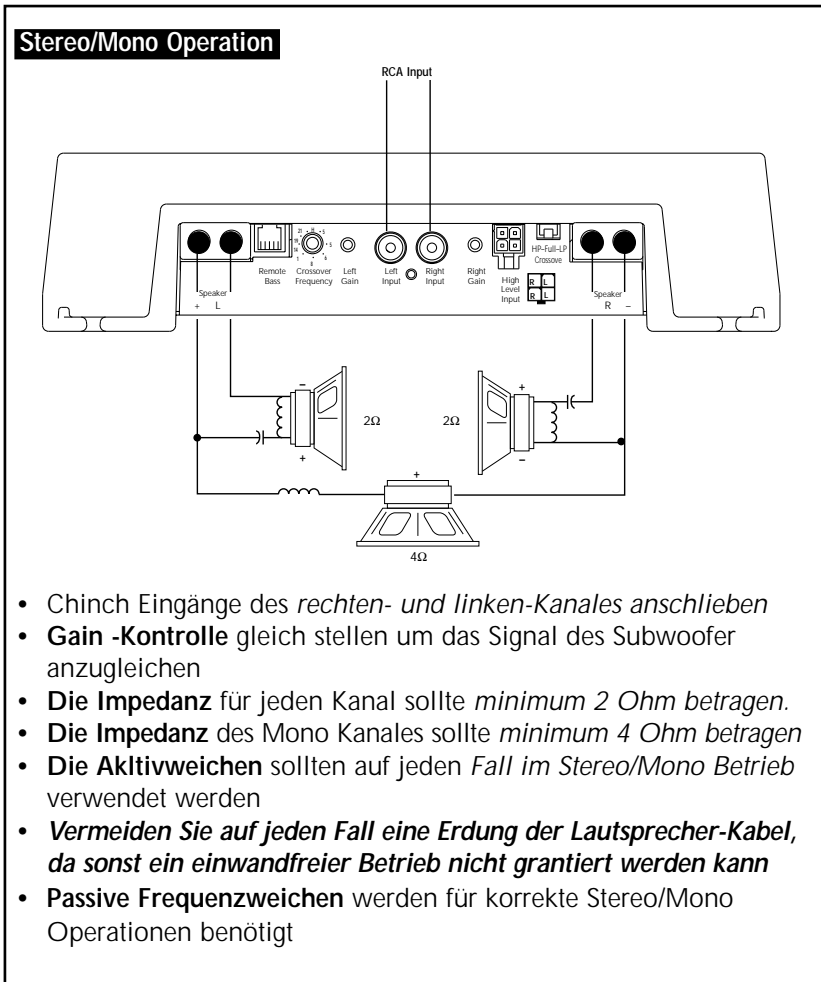

- Chinch Eingänge des *rechten- und linken-Kanales* anschließen
- **Gain -Kontrolle** gleich stellen um das Signal des Subwoofer anzugleichen
- **Die Impedanz** für jeden Kanal sollte *minimum 2 Ohm* betragen.
- **Die Impedanz** des Mono Kanales sollte *minimum 4 Ohm* betragen
- **Die Aktiwweichen** sollten auf jeden *Fall im Stereo/Mono Betrieb* verwendet werden
- **Vermeiden Sie auf jeden Fall eine Erdung der Lautsprecher-Kabel, da sonst ein einwandfreier Betrieb nicht garantiert werden kann**
- **Passive Frequenzweichen** werden für korrekte Stereo/Mono Operationen benötigt

**ATTENZIONE: SI PREGA DI LEGGERE LE SEGUENTI ISTRUZIONI PER L'INSTALLAZIONE DI QUESTO PRODOTTO. IL NON SEGUIRLE POTREBBE RISULTARE SERIAMENTE DANNOSO PER LA PERSONA O PER IL VEICOLO.**

## **INTRODUZIONE — ITALIANO**

---

Gli ingegneri Rockford hanno progettato la serie di amplificatori Punch per resistere all'ostico ambiente automobilistico mentre suonano con una musicalità superiore, offrendo un insieme versatile, affidabile ed efficiente. Trans•ana é un circuito a bassa tensione dello stadio preamplificatore del Punch che permette al suono di essere cristallino e reale anche in presenza di volumi molto elevati...tutto questo é accoppiato TOPAZ, un esclusivo circuito di massa impiegato per eliminare i problemi di rumore comunemente presenti negli impianti car audio. Il massimo della versatilità é raggiunto con l'impiego delle crossover. L'affidabilità é completamente garantita dall'impiego di un circuito di protezione chiamato NOMAD, mentre l'uso di MOSFET e della tecnologia DSM (Discrete Surface Mount) permette di raggiungere efficienze elevatissime. Il risultato finale di tutte queste tecnologie moderne é che gli amplificatori Punch suonano meravigliosamente e sono indistruttibili, a "prova di proiettile." Una spiegazione di queste tecnologie innovative, molte coperte da brevetti Rockford, sono descritte in un'altra sezione di questo manuale.

## **DOVE POSIZIONARLO**

---

### **Nel Bagagliaio**

Montando l'amplificatore su una superficie in verticale con le alette direzionate dall'alto verso il basso si garantirá un miglior raffreddamento dell'amplificatore.

### **Nell'abitacolo**

Montare l'amplificatore nell'abitacolo si avrá un funzionamento regolare se si garantisce un flusso d'aria sufficiente. Per l'installazione sotto un sedile, é necessario avere uno spazio di almeno 3 cm attorno a tutto l'amplificatore.

### **Installazione**

Per sicurezza, scollegare il polo negativo della batteria dell'auto prima di iniziare l'installazione.

### **Terminale B+ (cavo positivo)**

Il cavo positivo deve essere protetto da un fusibile a non piú di 45 cm dalla batteria. Terminare il cavo e installare il fusibile nel vano motore. Tutte le connessioni devono essere a prova d'acqua.



## Terminale GND (cavo negativo)

Decidere la lunghezza del cavo e terminarlo. Preparare la massa grattando la vernice dal telaio dell'auto ed eliminando tracce di olio o sporco. Fissare il cavo di massa al telaio con una vite.

## Terminale REM (Consenso di accensione)

Collegare il cavo REM ad un positivo presente solo ad autoradio accesa (normalmente il cavo pilota dell'antenna elettrica o il cavo accessori dell'autoradio). Se la sorgente non dovesse essere equipaggiata con queste uscite, la soluzione raccomandabile é di inserire un interruttore su un cavo positivo e connettersi all'amplificatore.

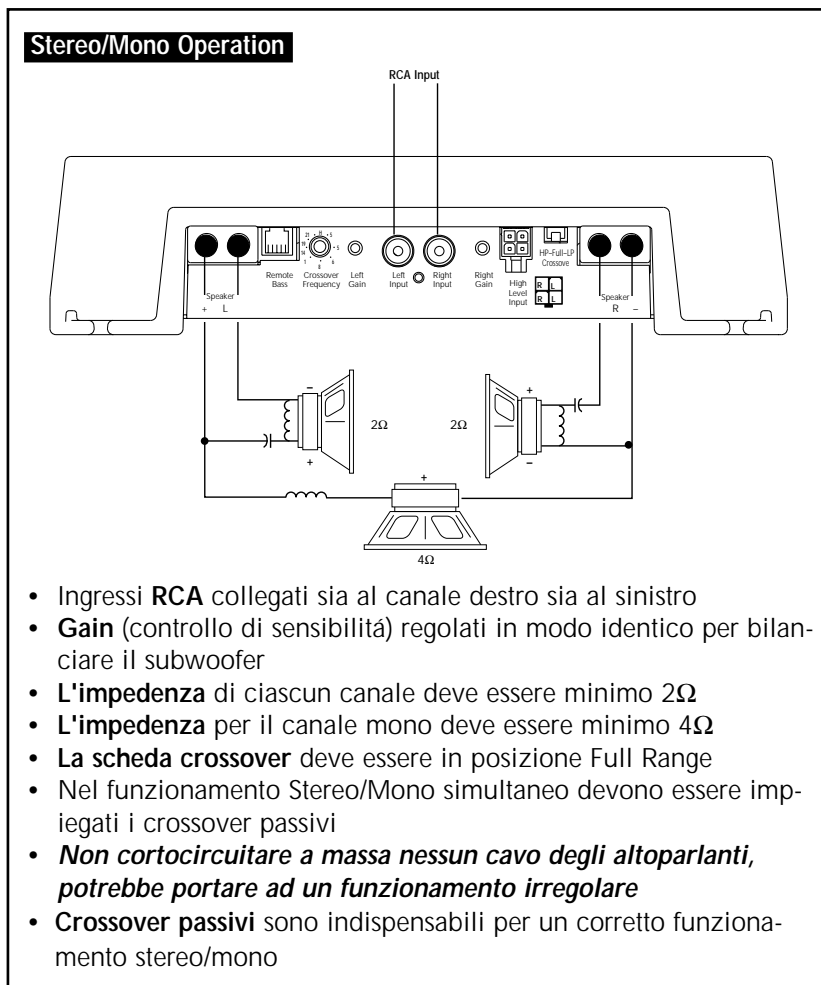

- Notes -

---

- Notes -

---

Installation assistance available at:

# RFTECH

[www.rockfordfosgate.com/rftech](http://www.rockfordfosgate.com/rftech)

## MADE IN THE USA

This product is designed, developed and assembled in the USA by a dedicated group of American workers. The majority of the components used in the construction of this product are produced by American companies. However, due to the global nature of their manufacturing facilities and the loudspeaker parts industry in general, some parts may be manufactured in other countries.



Rockford Corporation  
546 South Rockford Drive  
Tempe, Arizona 85281 U.S.A.  
In U.S.A., (480) 967-3565  
In Europe, Fax (49) 8503-934014  
In Japan, Fax (81) 559-79-1265